

# CHRIS WITOR.com

## Subframe Variations

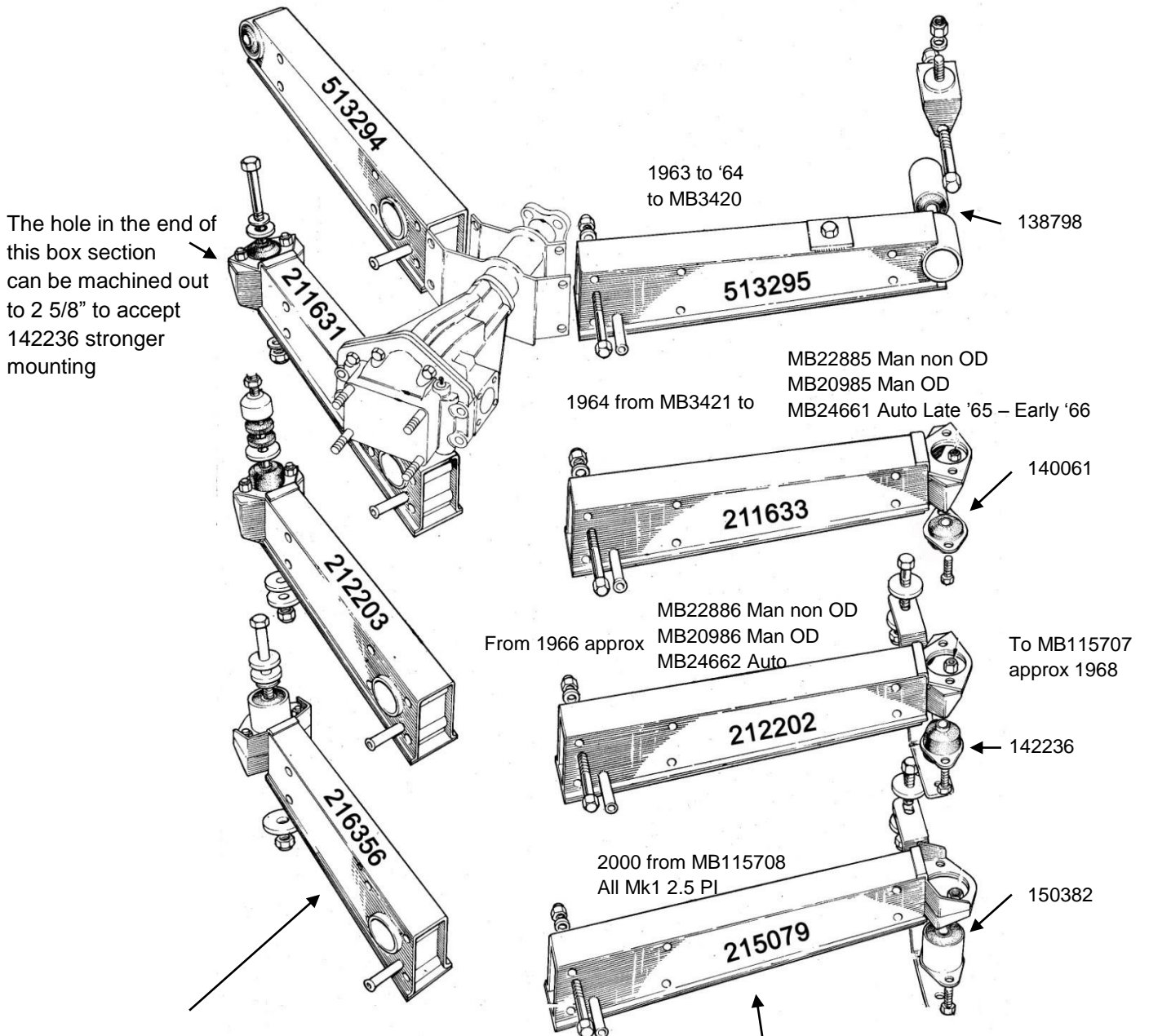

The hole in the end of this box section can be machined out to 2 5/8" to accept 142236 stronger mounting

1963 to '64 to MB3420

1964 from MB3421 to MB22885 Man non OD  
MB20985 Man OD  
MB24661 Auto Late '65 - Early '66

From 1966 approx MB22886 Man non OD  
MB20986 Man OD  
MB24662 Auto To MB115707 approx 1968

2000 from MB115708 All Mk1 2.5 PI

As Mk2  
Except Mk2 uses box section 216356 with improved exhaust mount.

Stag similar to Mk2 except box section 215159 uses relocated hand brake cable tube.

Stag anti vibration straps also differ

As Mk2  
Stag similar except 215160 uses additional exhaust hole & relocated handbrake cable tube.

## Subframe Mountings Used

- All four types

